



JUST A MINUTE... WHY YES!! APPARENTLY I AM
THE DECISION MAKER FOR THE COMPANY!!

DECISION MODELS

Introduction



Why this course ?

- Data Analytics has gathered a lot of attention during the last years.
Why ?
- Unprecedented availability of **Data**
- Ability to build **Models** based on this data
- Need of making good **Decisions** quickly (under **uncertainty**)

But...while **descriptive** and **predictive** analytics has become well-established, **prescriptive** analytics has just started to emerge.

The challenge is therefore to take advantage of the predicted future while understanding the implications of possible decision options.



Why this course ?

- One of the main objective of this course is to make students aware of decision models and optimization methods that can be used to derive decision options, to evaluate them and find optimal solutions:
- Transforming data in good decisions:
 - What should I do ?
 - Why should I do it ?



Communication matters

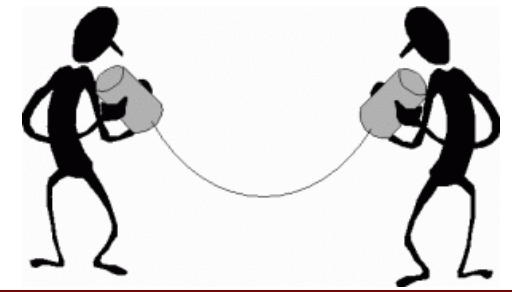

Try to think at one sentence definition for:

- Analytics
 - Descriptive
 - Predictive
 - Prescriptive
- Decision making
- Decision model
- Optimization





DECISION MODELS

Introduction Part II

Data Science - University Milano Bicocca



Data Science - University Milano Bicocca

Analytics

Analytics is the **discovery, interpretation, and communication** of meaningful **patterns in data**. Especially valuable in areas rich with recorded information, analytics relies on the simultaneous application of **statistics, computer programming and operations research** to quantify performance.

<https://en.wikipedia.org/wiki/Analytics>

The systematic **computational** analysis of data or **statistics**

<https://en.oxforddictionaries.com/definition/analytics>



A process in which a computer examines information using **mathematical** methods in order to find useful patterns

<https://dictionary.cambridge.org/dictionary/english/analytics>



Analytics

Analytics has emerged as a **catch-all term** for a variety of different business intelligence (BI)- and application-related initiatives.

<https://www.gartner.com/it-glossary/analytics/>

The field of data analysis. Analytics often involves studying **past** historical data to research potential **trends**, to analyze the **effects** of certain decisions or events, or to evaluate the performance of a given tool or scenario. The goal of analytics is to improve the business by **gaining knowledge** which can be used to make **improvements** or changes

<http://www.businessdictionary.com/definition/analytics.html>



Analytics



What is Analytics?

- Using **data** to build **models** that lead to better **decisions**
- Ultimately create **value**
- Can use big data or “small” data



Analytics

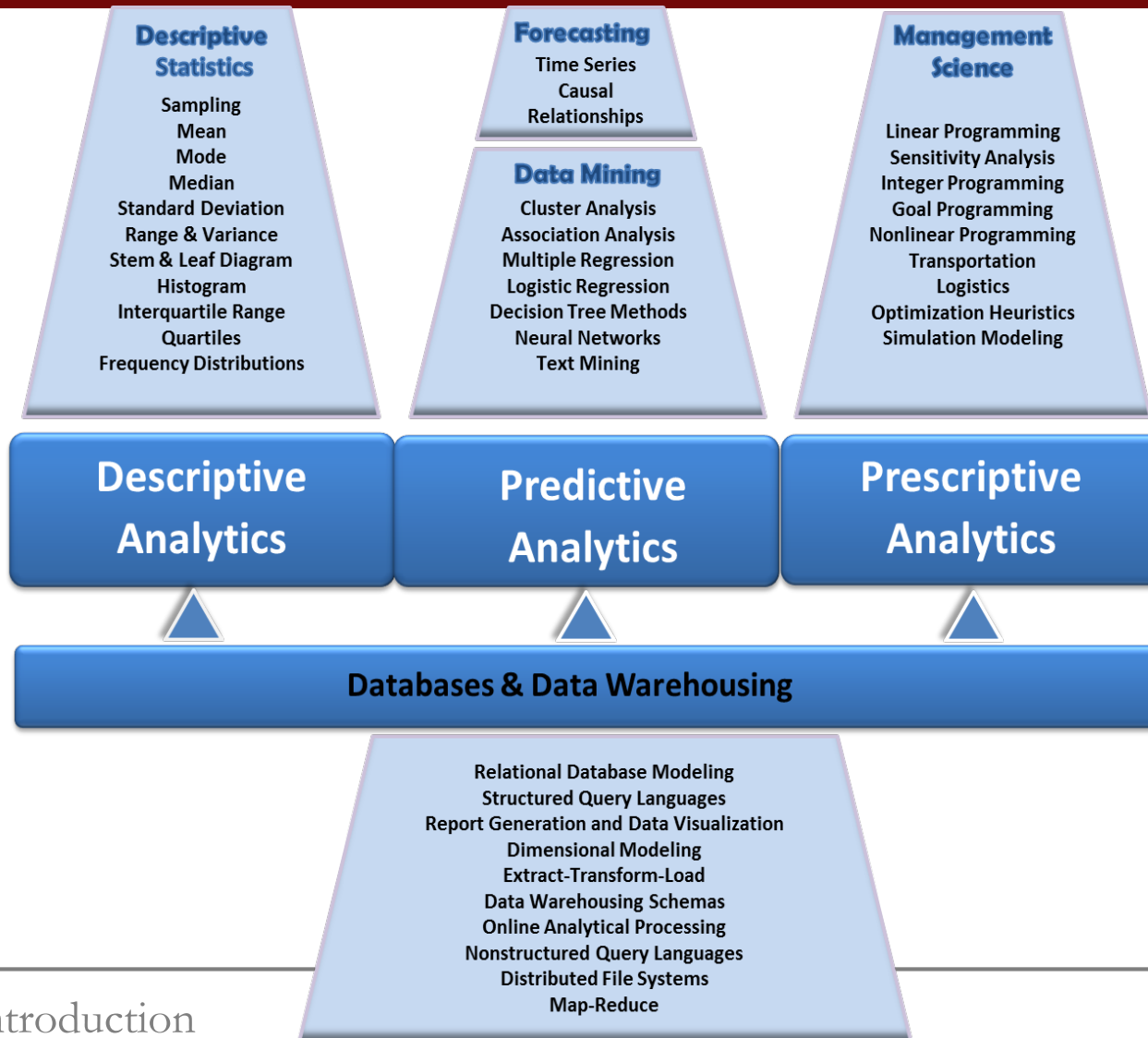

What is Analytics?

- Descriptive – finds patterns in the data
 - Summary statistics
 - Visualizations
 - Clustering etc.
- Predictive – predict different outcomes
 - Linear Regression
 - Logistic Regression, CART, Random Forests, ML etc
- Prescriptive – gives advice on actions to take
 - Optimization



What is Analytics?

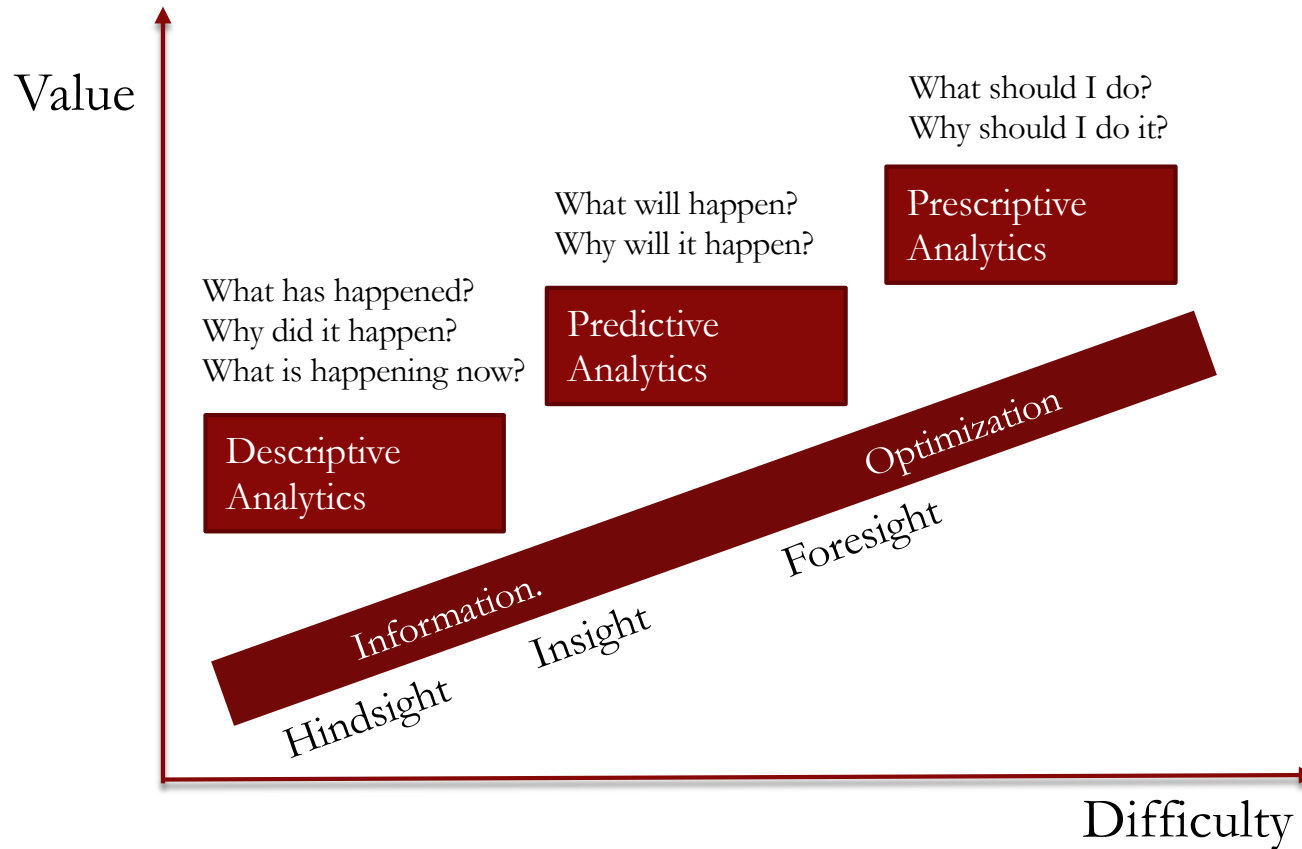

Gartner





DECISION MODELS

Introduction Part III



Descriptive Analytics

- Function:
 - describe the main features of available data
- Common tools:
 - sampling, mean, mode, median, standard deviation, range, variance, stem and leaf diagram, histogram, interquartile range, quartiles, and frequency distributions
- Displaying results:
 - graphics/charts, tables, and summary statistics such as single numbers



"Data don't make any sense,
we will have to resort to statistics."

Predictive Analytics

- Process:
 - Begin with descriptive analytics
 - Extract patterns from large data quantities
 - Correlate data types for explanation of near-term behavior – past and present
 - Estimate linear/non-linear behavior
- Example: by classifying past insurance claims, estimate the number of future claims to flag for investigation with a high probability of being fraudulent.

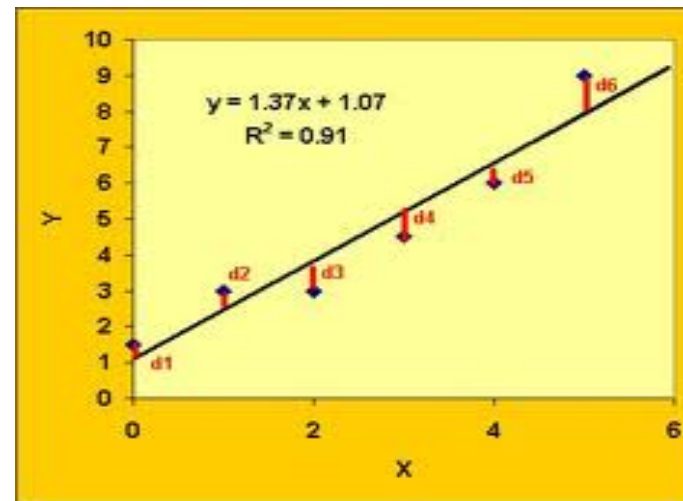

Predictive Analytics

- ◆ Function:
 - draw conclusions and predict future behavior



Prescriptive Analytics

- **Process:**

- Begin with predictive analytics
- Determine what should occur and how to make it so
- Identify the mitigating factors that lead to desirable/undesirable outcomes
- “What-if” analysis with local or global **optimization**

Ex: Find the best set of prices and advertising frequency to maximize revenue and, the right set of business moves to make to achieve that goal

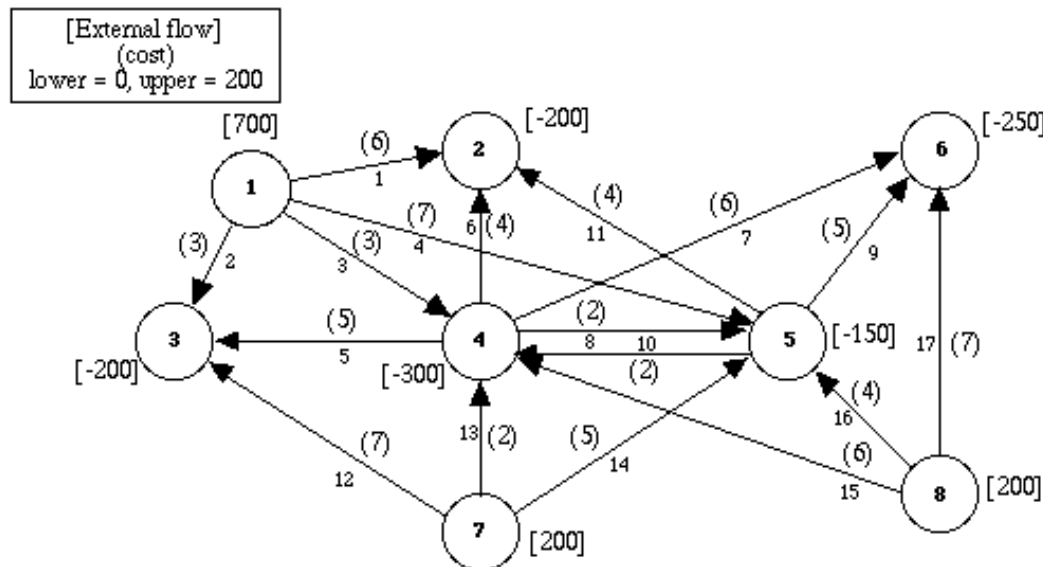

“Make it so”

Copyright (except where referenced) 2014-2016
Stephen H. Kaisler, Frank Armour, Alberto Espinosa and William H. Money



Prescriptive Analytics

- Function:
 - make decisions based on data
- Common models:
 - linear programming
 - sensitivity analysis
 - integer programming
 - goal programming
 - nonlinear programming
 - simulation modeling



"What it comes down to is this thing is capable of telling us a lot more than we really want to know."



Example: Industry 4.0

Industry 4.0 indicates the current trend of automation and data exchange in manufacturing technologies in order to facilitate manufacturing.

For example, consider the case of **predictive maintenance** in which sensors generate a multitude of data dealing with indicators of equipment's degradation.

Descriptive analytics algorithms monitor the current condition of the manufacturing system and provide alerts in cases of abnormal behaviours. This is achieved by comparing the actual measurements of several parameters that constitute indicators of degradation.

When they vary from the normal values, an alert triggers the **predictive analytics** algorithms. The alert is evaluated and, if it indicates a potentially hazardous state of the manufacturing equipment, the predictive analytics algorithms generate predictions about the future health state of the manufacturing system, e.g. a prediction about the time-to-failure.

On the basis on this prediction, **prescriptive analytics** algorithms are able to provide recommendations about the optimal mitigating actions and the optimal time for their implementation in a way that the expected loss and the risk are minimized.



Example: Transportation

The **traffic congestion control** attempts to release the city centers from the traffic jams.

Currently, sensors can detect vehicles in corresponding areas.

Applying **descriptive analytics** we can use this data along with historical data from traffic monitoring network to derive outcomes such as level of traffic in different areas at different times in an aggregated form and describe traffic flow.

These results feed into the **predictive analytics** algorithms can provide predictions about the traffic flow (congestion level) of the system by taking into account contextual information (e.g. peak times).

Then these predictions trigger the **prescriptive analytics** algorithms which can suggest real time reactions with the aim to reduce the congestion level proactively (e.g. traffic lights control), or also take strategic decisions on the network viability in order to reduce congestions.



Communication matters

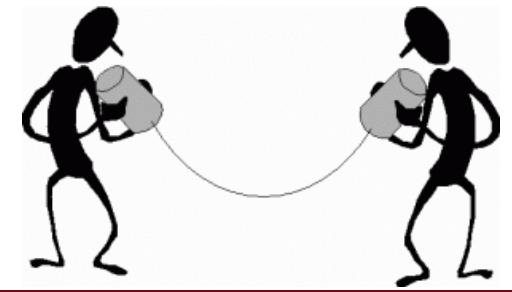

Try to re-think at one sentence definition for:

- Analytics
 - Descriptive
 - Predictive
 - Prescriptive



Would you changed your definitions now ?





DECISION MODELS

Introduction Part IV



Decision making

The thought **process** of selecting a logical **choice** from the available options.

When trying to make a good **decision**, a person must consider all the **alternatives** and **weight** the positives and negatives of each option.

For **effective** decision making, a person must be able to **forecast** the outcome of each option as well, and based on all these items, determine which option is the best for that particular situation

<http://www.businessdictionary.com/definition/decision-making.html>

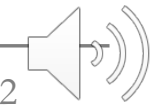

Decision making

Decision-making is a **goal-oriented** process.

Decisions are usually made to achieve some purpose or goal.

To make informed decisions we can use Analytics

Types of Decision Making Problems

- Unstructured problems
 - * Problems that are new or unusual and for which information is ambiguous or incomplete.
 - * Problems that will require custom-made solutions.
- Non-programmed decisions
 - * Decision that are unique and nonrecurring.
 - * Decision that generate unique responses.

Types of Decision Making Problems

- Structured problems
 - * Their goals are clear.
 - * Are familiar (have occurred before)
 - * Are easily and completely defined (information about the problem is available and complete)
- Programmed decision
 - * A repetitive decision that can be handled by a routine approach.



Types of Decision Making Problems

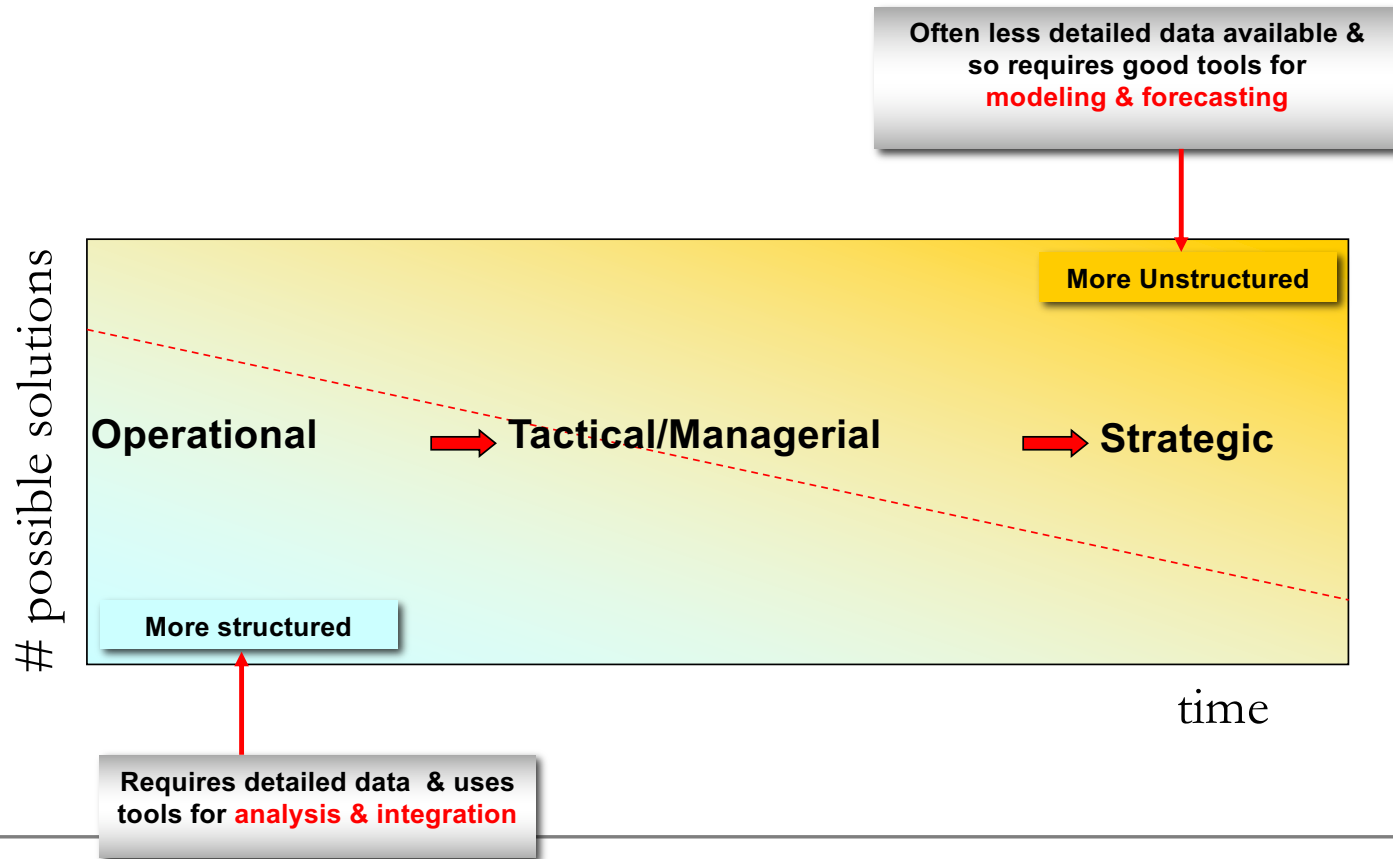

Decision Making Conditions

Certainty

- A situation in which the outcomes of all possible decisions are known and therefore the we can make accurate decisions.

Uncertainty

- A situation in which there is no certainty of the outcomes of the possible decisions
- When a probability estimation of the outcome is known then we might be able to estimate the likelihood of certain outcomes (this condition is also referred to as **Risk**)



Decision model

A model refers to some form of symbolic representation of our assumptions about the reality

A **Decision Model** must be able to **predict** the **outcomes** of **decisions**.

It maps the **relationships between elements** of the decision and the forecasted results in order to **understand or control** the problem.

The decision model predicts what will happen if a certain action is taken.

Why do we use models?

Enhance our understanding of the world to improve our decision making

Elaborate a scientific method to solve a problem

Duplicable (repeatable) Reduce bias

Optimization

Optimization is at the heart of almost all machine learning and statistical techniques used in data science.

Optimization is at the heart of every major business, social, economic, and personal decision, that is taken by an individual person, collective representation of people, or intelligent machines and software agents.

<https://towardsdatascience.com/a-quick-overview-of-optimization-models-for-machine-learning-and-statistics-38e3a7d13138>

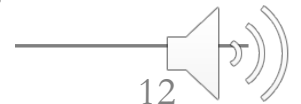

Optimization

Optimization : Maximizing or minimizing some performance function relative to some set of possible solutions meeting a set of possible constraints.

The function allows comparison of the different choices for determining which might be “best.”

Optimization is achieved usually by using techniques of operations research.

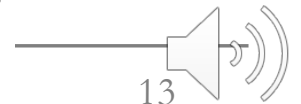

In conclusion... the course objective is...

Using Descriptive, Predictive and Prescriptive Analytics to Make Decisions / Take Actions

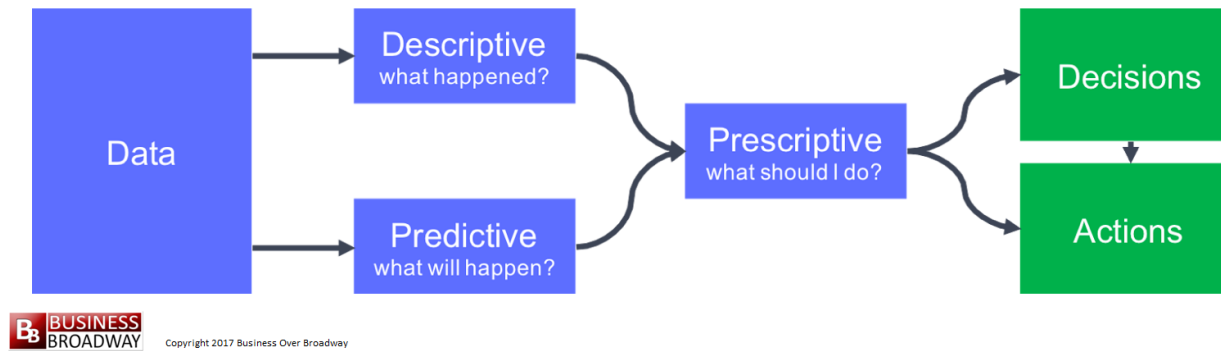

- Inspire you to use all kinds of analytics in your career
- Not just hearing about analytics, but acquire competences for creating your own models
- Throughout this course we will study how various mathematical models can be implemented and analyzed

Communication matters

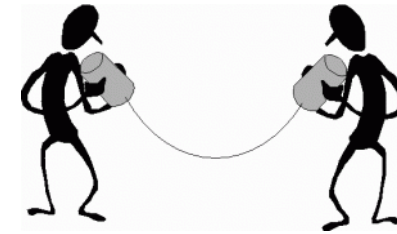

Try to re-think at one sentence definition for:

- Decision making
- Decision model
- Optimization

Have you changed your definitions ?

